

**.nz**

# Local governance and policy framework

APTLD Non-Technical Training  
June 2007

## The .nz Domain Name Space

- No legislation covering the .nz domain name space
- .nz domain name space operates as a Shared Registry System (SRS)
- Authorised registrars have access to the register and full responsibility over their domain names
- The SRS is governed by a series of .nz policies and procedures and formal agreements

## Who looks after .nz

- InternetNZ – delegated responsibility for .nz
- .nz Oversight Committee (NZOC) – sub-committee of InternetNZ with oversight of .nz operation
- Domain Name Commission (DNC) – an operational office of InternetNZ
- NZRS – Subsidiary company of InternetNZ responsible for operating the .nz register

## How they fit together.....

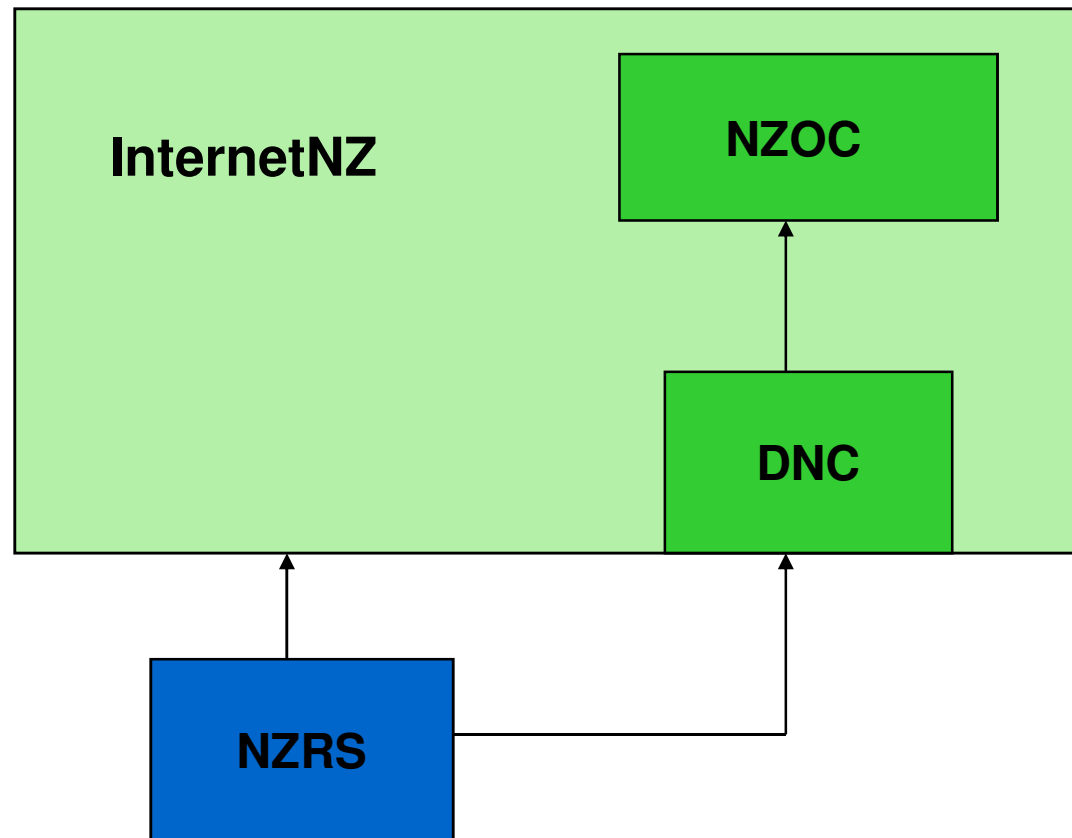

# The .nz Domain Name Space

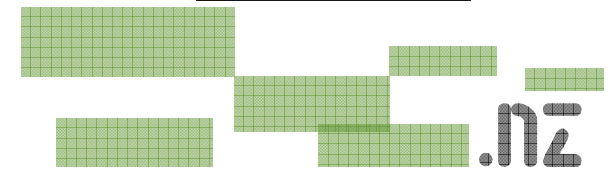
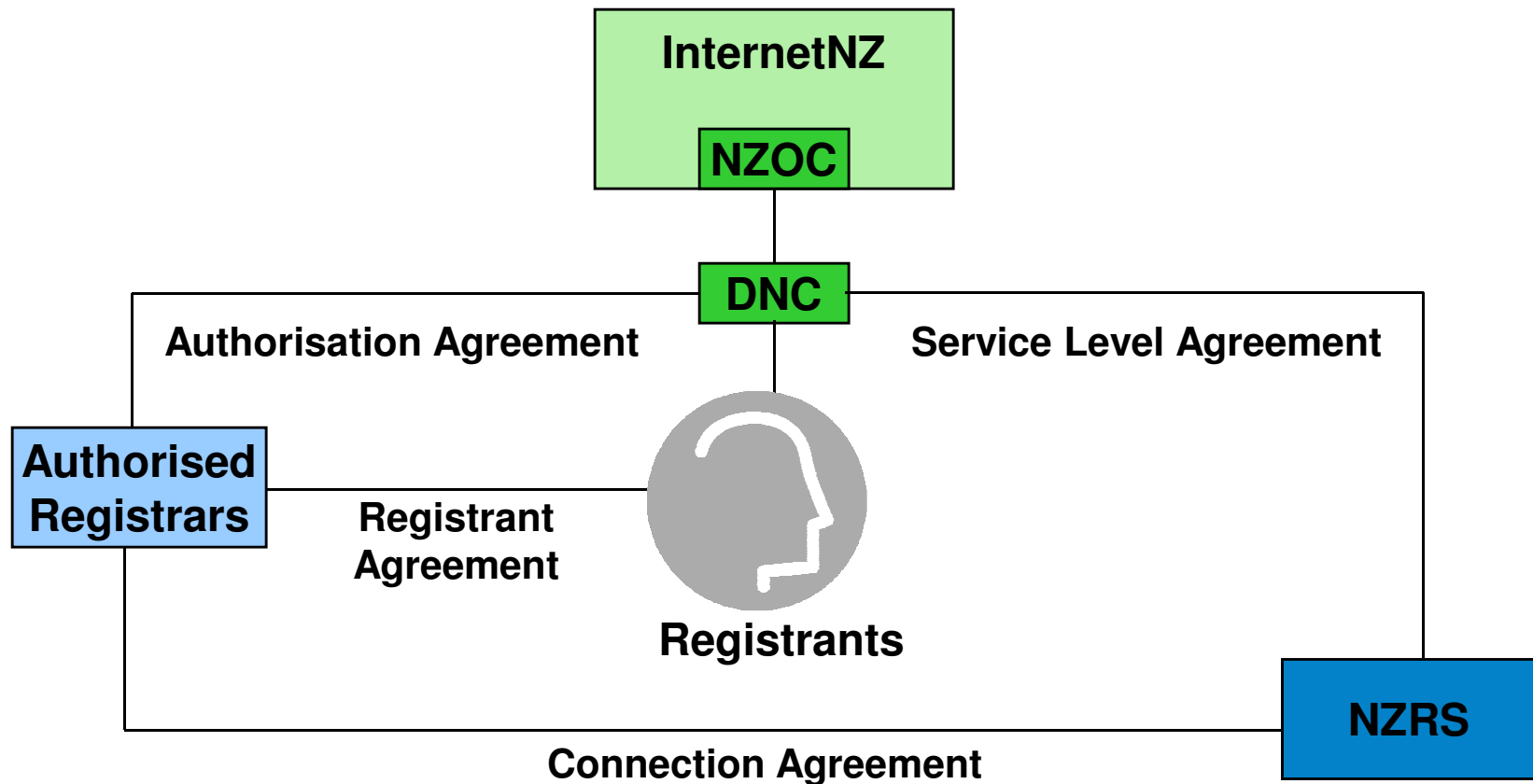

# .nz policies and procedures

[www.dnc.org.nz/policies](http://www.dnc.org.nz/policies)

- Authorisation of registrars process
- Connection process
- Change of registrant
- Dispute and complaints process
- Dispute Resolution Service
- Investigations and Inquiries process
- Privacy policy
- Process on de-authorisation of a registrar
- Roles and Responsibilities
- Registering, Managing and Cancelling domain names
- Transfer to another registrar
- WHOIS server policy
- Zone Transfer policy

## NZOC

### ○ .nz Oversight Committee

- Membership of 5 - 7
- Includes InternetNZ President ex-officio
- Selected by InternetNZ Council for varying terms
- Not elected
- Registrars not eligible for selection

## NZOC

Responsibilities include:

- Delegated responsibility by InternetNZ Council to have formal oversight of .nz
- Approve budget of DNC (funded by management fee charged to NZRS)
- Set .nz policy and procedures
- Manage the performance of the DNC
- Overall responsibility for compliance of registrars, enforcing serious sanctions and ensuring SLA with NZRS met

## Office of the DNC

Responsibilities include:

- Authorising registrars
- Monitoring compliance with .nz policies and procedures
- Developing policies and procedures under the oversight of NZOC

## DNC responsibilities contd

- Handling complaints that arise in the operation of the .nz market
- Protecting the rights and relationships of all parties in the .nz market
- Convening a Registrar Advisory Group
- Monitoring the performance of NZRS against the Service Level Agreement (SLA)

## SLA with NZRS

- Includes performance standards
- 99.9% system availability
- Response times for key transactions
- Response times for responding to faults, queries, requests
- Reporting requirements
- Reported against monthly by NZRS to the DNC
- Issues escalated to NZOC by DNC if required

## Key features of the .nz SRS

- Registrant focused
  - Transfer at any time for no cost (except during registration grace period)
  - Registrars must provide the UDAI to allow transfer
  - Full period of registration must be recorded on the register
  - Operates on an automatic renewal function
  - Restrictions on when a domain name can be cancelled

## Key features contd

- Registrant focus (contd)
  - 90 day pending release period
  - Registrars required to register domain name in the name of the party requesting the registration and who will be using it
  - Terms and Conditions for registrants must be approved by the DNC
  - Prohibits notices to registrants that appear as a renewal notice, or specify particular domain names

## Key features contd

- Features also for registrars
  - Flexibility of one month to 120 month registrations
  - Billing period defaults to one month after transaction
  - Five day registration and renewal grace periods
  - Not required to accept transfers
  - Sanctions can be imposed on registrars who breach .nz policies and procedures
  - Professional liability insurance taken out to cover the market, incorporates all authorised registrars

## Key responsibilities on registrars

### ○ To registrants

- maintaining stable connection and authorisation status
- complying with all .nz policies and procedures
- fully and accurately disclose all terms and conditions regarding domain name services
- protecting registrant's information and only using information as authorised
- correcting any errors in the register when requested

## Key responsibilities on registrars

### ○ To NZRS

- meeting all technical requirements and submitting relevant data in the correct format
- only access the register to manage domain names for which they are the registrar
- comply with all registry's policies and directions regarding access to the register
- ensure no unauthorised access to the register through their connection

## Key responsibilities on registrars

### ○ To InternetNZ

- complying with all .nz policies and procedures
- safeguarding the rights of registrants
- advising the DNC if anything arises that may impact on their ability to be a registrar
- not engaging in any activity with does, or could, bring management of the .nz domain name space into disrepute
- take full responsibility for the actions of any re-sellers

## What registrars can expect

### ○ From registrants

- all information they provide is accurate and complete
- keep the registrar informed of changes
- ensure the UDAI is kept confidential and safe
- that they have the right to use a domain name
- that they use the registrar's services for lawful purposes only
- they comply with any order of authority having jurisdiction

## What registrars can expect

### ○ From NZRS

- they maintain a quality register and access to that register
- access to sufficient technical and customer service support
- protection of registrar's personal information against unauthorised access etc
- respect the relationship between registrars and their registrants

## What registrars can expect

### ○ From InternetNZ

- providing and maintaining .nz policies
- ensure high performance from NZRS
- maintain active oversight and management of the .nz domain name space
- authorise registrars, and perform all responsibilities in a fair, transparent and timely manner
- convene a registrar advisory group

## Registrars

- A list of authorised registrars can be seen at <http://www.dnc.org.nz/registrars>
- Authorised registrars can display the official logo

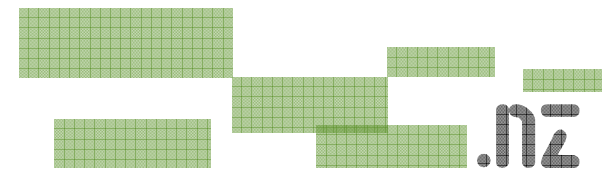

[www.dnc.org.nz](http://www.dnc.org.nz)

[www.internetnz.net.nz](http://www.internetnz.net.nz)

[www.nzrs.net.nz](http://www.nzrs.net.nz)